

DCC SERVO DECODER MASTER - DIY

C1	100u/35V	1
C2, C3	100u/25V	2
C4, C5	100n	2
C6	1000u/35V	1
D1	SB260	1
D2	1N4007	1
D3	1N4148	1
IC1	PIC12F629-I/P	1
IC2	LM317/350	1
IC3	6N137	1
IC4	7805	1
IC socket	SOKL08	2
X1-4	3 pinhead	4
X5	DG306-5.0-3P11	1
X6, X7	DG306-5.0-2P11	2
X8	2 pinhead + cap	1
P1	PT10VK-2.5	1
R1	820R	1
R2	91R	1
R3	22k	1
R4	1k5	1
R5	1k	1
TL1	TACT-67N-F	1
U1	KBU1010	1
X5	Output to Slave module	
X6	Power supply (10-15V AC/DC)	
X7	DCC	

Install wire bridge at firts (red lines on picture).

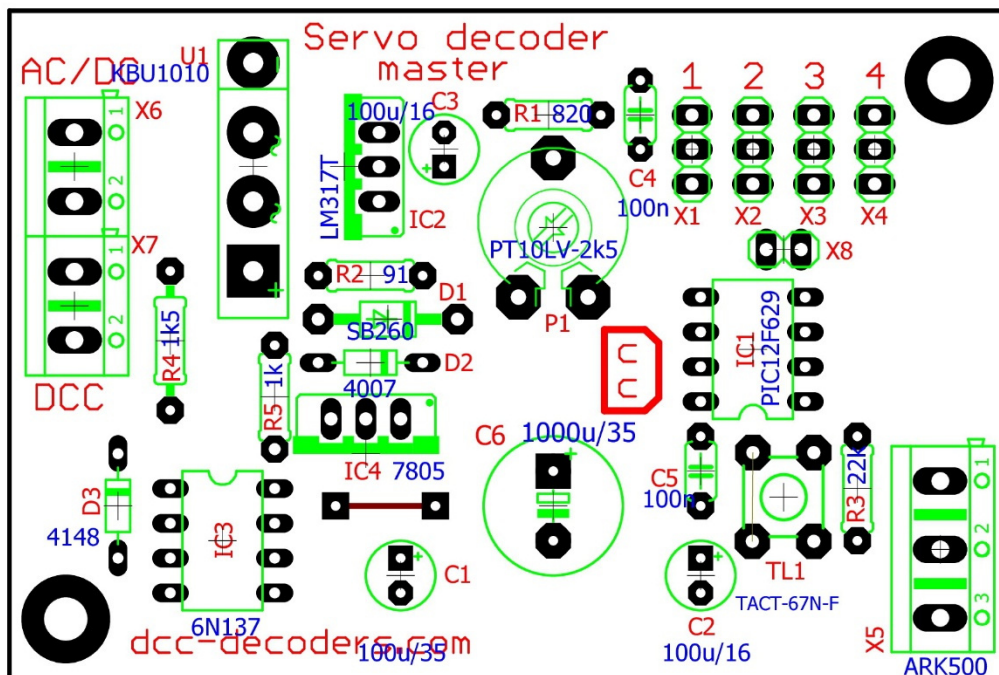

Programming:

1. method: connect to programming track - see table 1

2. method: normal mode (only decoder address):

- press the program button and hold on!

- enter the address on your hand controller and change direction as you command other accessories. Only 1 address! Release button.

- output addresses are consecutive, if you entered number 3, the addresses will 1,2,3,4. If 170, addresses will 169,170,171,172 (see table 2).

JUMPER:

Disconnect in case if the Slave module is connected and want to change values in CV.

Connect Master to Programming track (DCC terminal), remove all Jumpers except module you want to program.

If the Jumper is disconnected, you can't modify CVs or command device!

CVa	CVb	Values	Default	Description
513	1	1 ... 63	1	Decoder address (low bites)
515	3	1 ... 105	50	Angle of servo 1
516	4	1 ... 105	50	Angle of servo 2
517	5	1 ... 105	50	Angle of servo 3
518	6	1 ... 105	50	Angle of servo 4
519	7	10	10	Permanent value
520	8	13	13	Permanent value
521	9	0 .. 7	0	Decoder address (high bites)
541	29	128	128	Permanent value (128 = accessory decoder)
545	33	32 ... 255	78	Time of impulse, affect servos speed
546	34	0 or 1	1	0 - doesn't save servos position 1 - does save servos position
547	35	1 ... 255	1	Speed of servo 1
548	36	1 ... 255	1	Speed of servo 2
549	37	1 ... 255	1	Speed of servo 3
550	38	1 ... 255	1	Speed of servo 4

CVa - „Lenz system” - accessory address over 513

CVb - „Roco system” - accessory address under 255

CV 1/ 513	Outputs no.	CV 1/ 513	Outputs no.
1	1,2,3,4	33	129,130,131,132
2	5,6,7,8	34	133,134,135,136
3	9,10,11,12	35	137,138,139,140
4	13,14,15,16	36	141,142,143,144
5	17,18,19,20	37	145,146,147,148
6	21,22,23,24	38	149,150,151,152
7	25,26,27,28	39	153,154,155,156
8	29,30,31,32	40	157,158,159,160
9	33,34,35,36	41	161,162,163,164
10	37,38,39,40	42	165,166,167,168
11	41,42,43,44	43	169,170,171,172
12	45,46,47,48	44	173,174,175,176
13	49,50,51,52	45	177,178,179,180
14	53,54,55,56	46	181,182,183,184
15	57,58,59,60	47	185,186,187,188
16	61,62,63,64	48	189,190,191,192
17	65,66,67,68	49	193,194,195,196
18	69,70,71,72	50	197,198,199,200
19	73,74,75,76	51	201,202,203,204
20	77,78,79,80	52	205,206,207,208
21	81,82,83,84	53	209,210,211,212
22	85,86,87,88	54	213,214,215,216
23	89,90,91,92	55	217,218,219,220
24	93,94,95,96	56	221,222,223,224
25	97,98,99,100	57	225,226,227,228
26	101,102,103,104	58	229,230,231,232
27	105,106,107,108	59	233,234,235,236
28	109,110,111,112	60	237,238,239,240
29	113,114,115,116	61	241,242,243,244
30	117,118,119,120	62	245,246,247,248
31	121,122,123,124	63	249,250,251,252
32	125,126,127,128

