

GRADE CROSSING MODULE - DIY

- the module commands 6 LEDs, a relay for a sound module and 2 micro servos
- suit for DC and DCC system as well
- output for 6 LEDs: 4x flashing red as warning lights and 2x flashing white (Eastern Europe version) as a free grade lights
- 2 input for sensors
- 2 output for a micro servo (moving grade barriers)
- output for a Sound module (5V DC)
- adjustable servo angle range between 0 and 180 degree
- manual control
- recommend power supply: 10-12V AC/DC /10-15VA

Description:

When the crossing grade is free the warning LEDs are off, the flashing white LED indicates free grade crossing (optional).

As the train covers the sensor, the red lights start flashing and the relay activates the Sound module. After 2 seconds the gates come down slowly - servos are active.

Keep flashing until the sensor stay uncovered for at least 1,5 seconds (the last wagon leaves the sensor), then the gates come up, the warning lights and sound will go off.

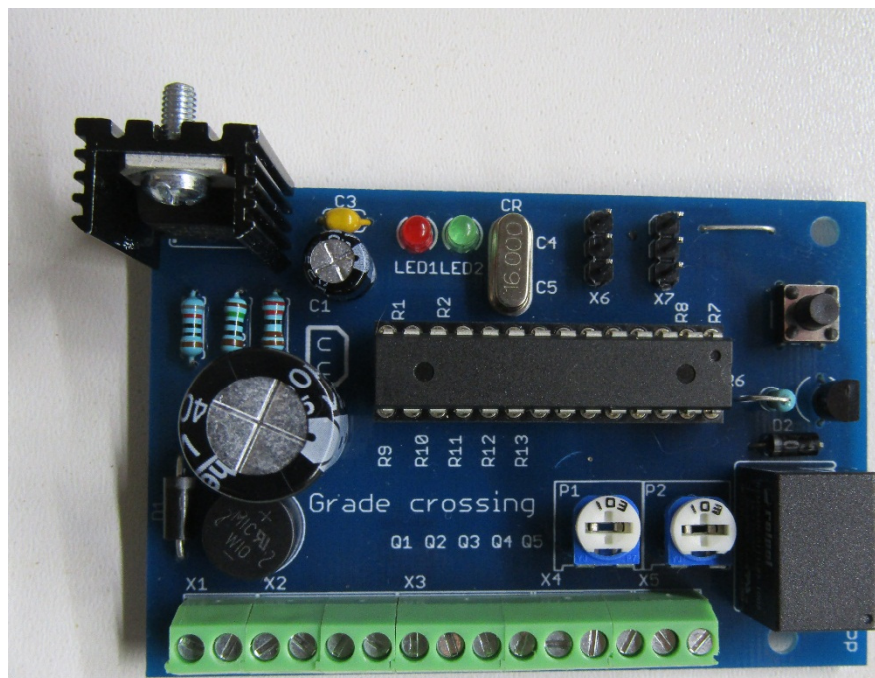

- 1 - AC/DC
- 2 - AC/DC
- 3 - +5V out
- 4 - GND out (sensor)
- 5 - sensor1
- 6 - sensor2
- 7 - +5V (common anode)
- 8 - warning red LED1
- 9 - warning red LED2
- 10 - free gate white LED
- 11 - n/a
- 12 - n/a
- 13 - manual start
- 14 - sound module out GND
- 15 - sound module out +5V

1 2 3 4 5 6 7 8 9 10 11 12 13 14 15

Using with Double infra sensor board:

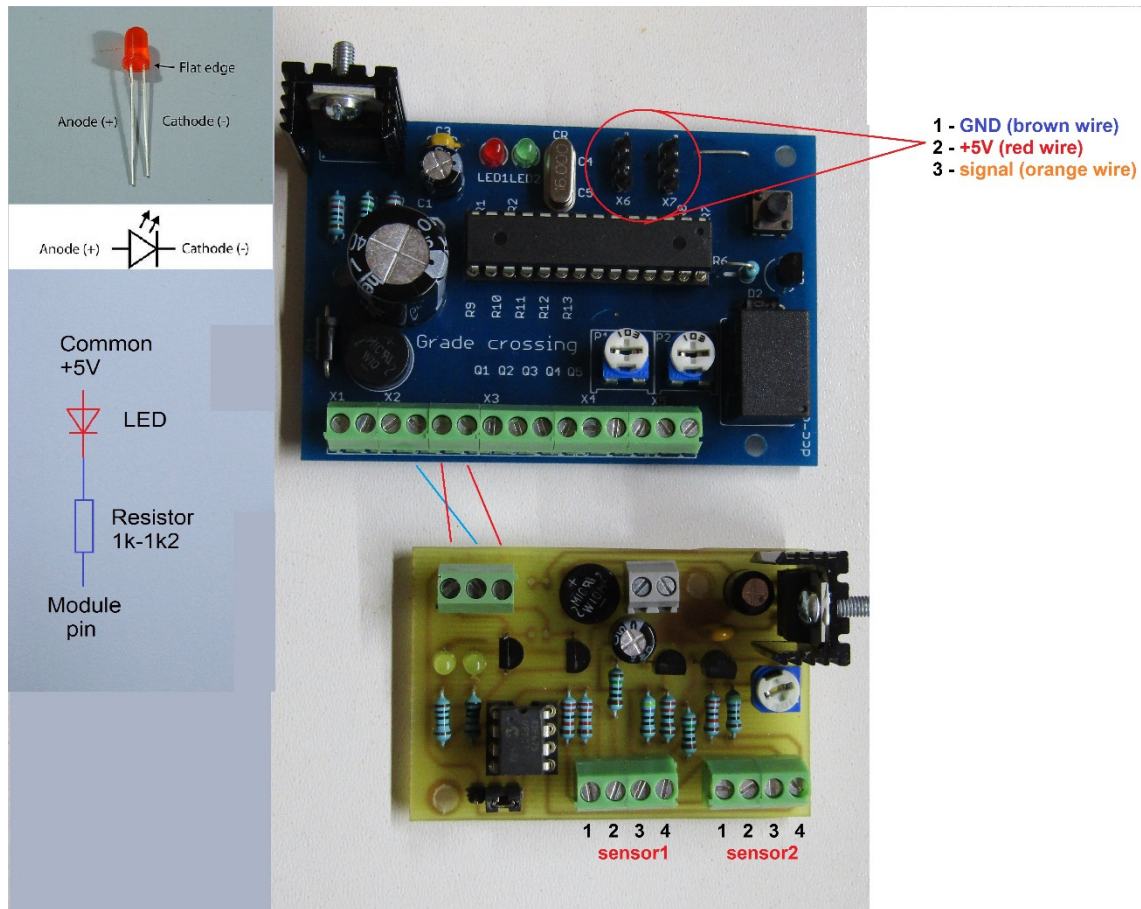

Using with TCRT5000 infra sensor:

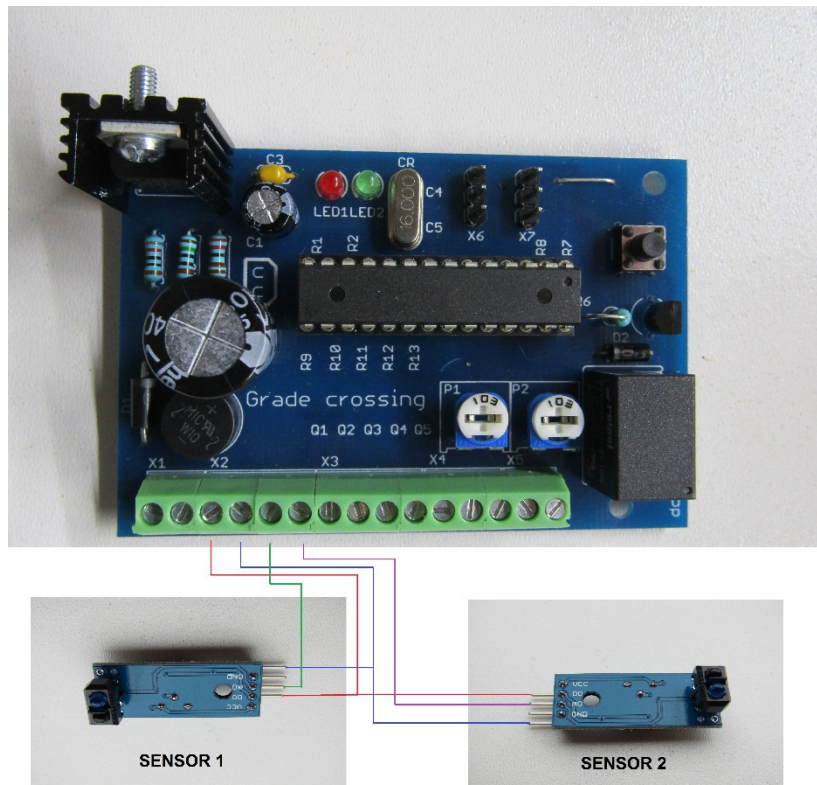

Setting:

- connect IR sensors following picture 2 or 3
- connect LEDs (semaphore). Do not forget to use resistors (1k - 1k5) to reduce voltage for LEDs!
- connect power supply between 10-12V AC or 12-15V DC
- the White LED start flashing
- cover the first sensor. Both Red LEDs start flashing and the relay clicks after a few seconds (output to a sound module is active)
- cover the second sensor and uncover it. The ending sequence will be started (see: Description)
- if all work well, connect micro servos and try it again. Pay attention to the polarity of servos!

Setting arms position (servo range):

- press button on board
- LED2 goes on - turn potentiometer P2 to set up the maximum position of the arm
- press button once again
- LED1 goes on - turn potentiometer P1 to set up the minimum position of the arm
- press button once again, LED1 and LED2 go off, values will be stored into memory

Manual control:

- connect pushbutton between terminal X4.3 and GND (X2.2)
- press button to start sequence and once again to end sequence

You can add any kind of pushbutton to operate sequence. Sensors are not working if the sequence has been activated manually.

Installation:

- install wire jumper first
- place SMD components
- continue with resistors, diodes, LEDs, crystal and IC socket
- place rectified, transistor, terminals and the biggest components

